

QUICKSNAP Round Column Installation Instructions

Mate the two pieces together of both the top and bottom mounting plates keeping in mind that the position of the join of the cap and base covers will be the same as the position of the mounting plate join (refer to diagram A).

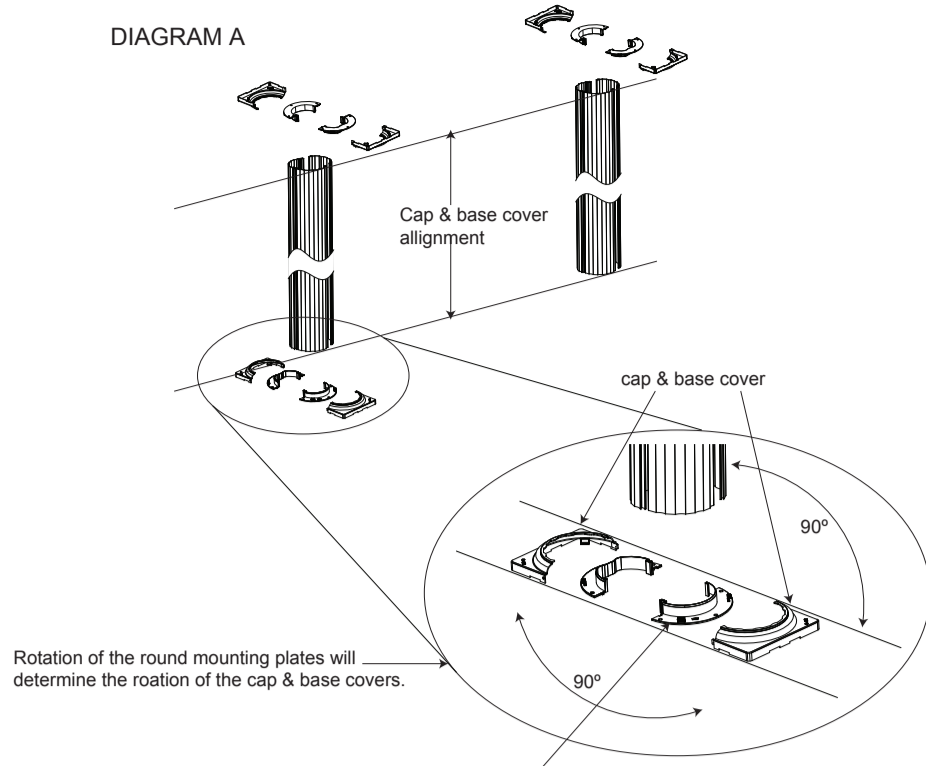

If using the column to wrap an existing column, secure both mounting plates using suitable fasteners ensuring that the indentation of the mounting flanges are in the same position top and bottom.

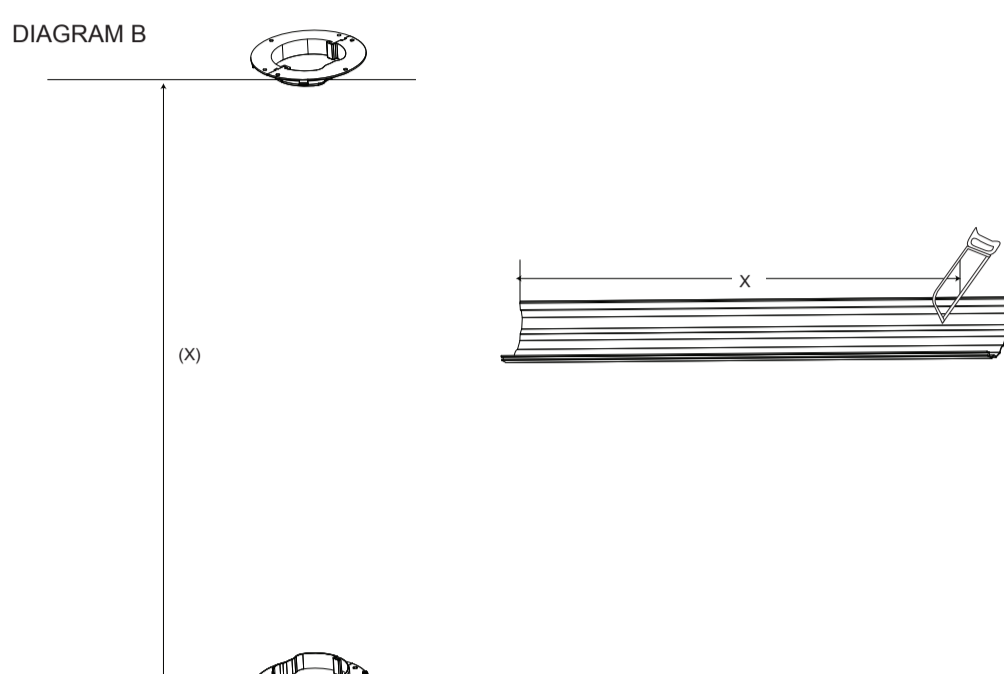

If the column is being used for stand alone structural application, mark the position and rotation of top and bottom mounting plates but secure the top mounting plate only.

NOTE: fasteners are not included for securing the mounting plates and it is the installer's responsibility to ensure proper fasteners are used for the mounting surface.

Measure the clear opening and cut each piece of the column separately before assembling.

For stand alone structural applications:

With the column pieces laying horizontal and ensuring that the ends of each piece are flush, secure the first 2 joins of the 3 pieces around the mounting plates by rotating male hooks into female hooks. To secure the final join, beginning at the base of the column working up, push firmly on the final join until column locks in place (diagram C).

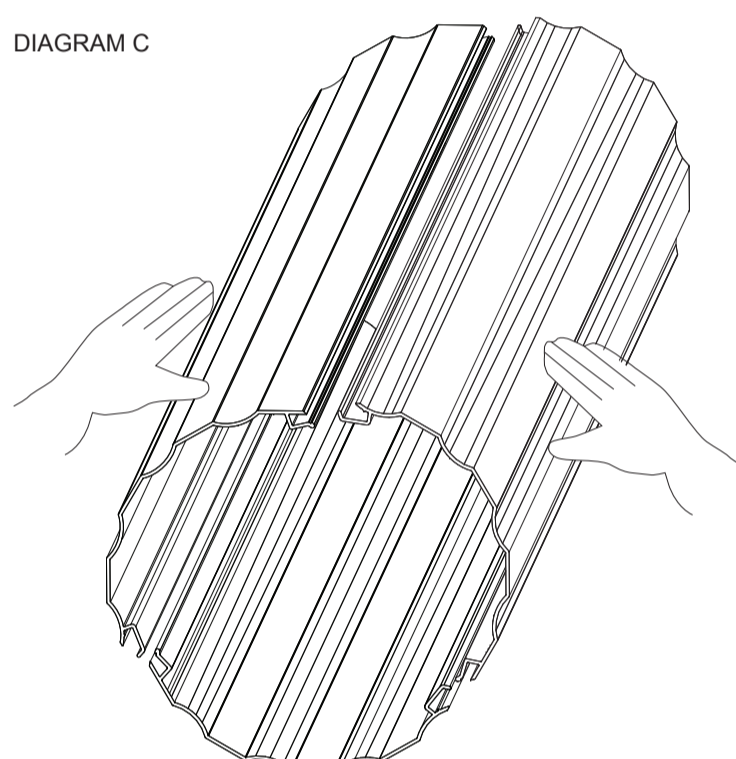

Fit the bottom mounting plate into the column and slide the column up over the top mounting plate. Rotate the bottom mounting plate so that the join is in the same position as the top mounting plate. Secure the bottom mounting plate using suitable fasteners for mounting surface. Rotate the column so that the center of a flute is in line with the join of the 2 piece mounting plate (diagram D).

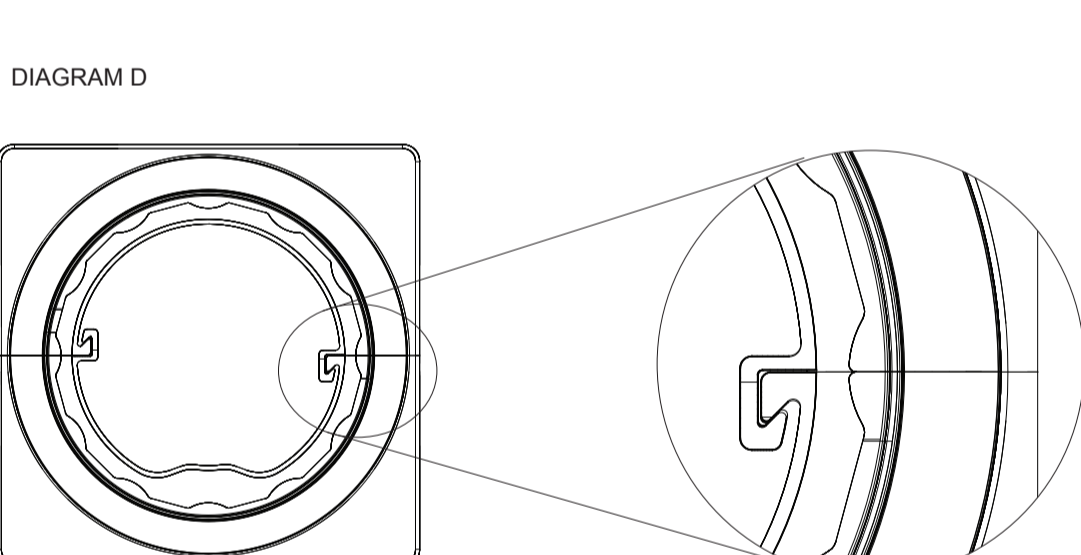

This will ensure proper fit of the cap & base covers around the column. Secure the column to the mounting plates top and bottom using 3/4" self-drilling screws.

For wrap around applications:

Secure the first 2 joins of the 3 pieces around the mounting plates by rotating male hooks into female hook. Rotate the column so that the final join is in line with the indentation on the mounting plate flange (Diagram E).

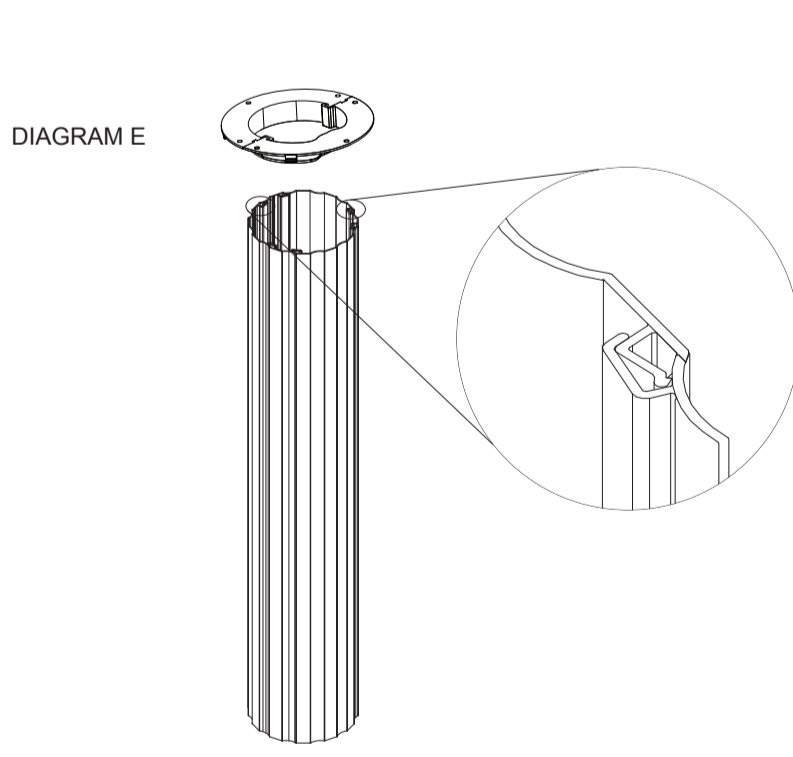

On the opposite side, place a temporary screw through the column into the bottom mounting plate to hold column in place. Beginning at the base of the column working up, secure the final join by pushing firmly at joint until it fully locks together. Remove the temporary screw and rotate the column so that the center of a flute is in line with the join of the 2 piece mounting plates (Diagram D). This will ensure proper fit of the cap & base covers around the column. Secure the column to the mounting plates top and bottom using 3/4" self-drilling screws.

Secure the cap and base pieces in place by sliding the hooked portion of the cap or base into the hooked portion of the mounting plates. Fasten the two pieces of the cap or base using # 10x 3/8" screws in predrilled holes on each side. (DIAGRAM F)

